

## Improved Features

# STANLEY MITRE BOXES

### No. 60MB—WITH SAW

1. Mitre Box can be set to cut any angle from 45° to 90°.
2. Quadrant is numbered for sawing 4, 5, 6, 8, and 12 sided figures. Swivel is fitted with a pin which locks into the numbered index holes.
3. Catches hold the saw above work so that both hands can be used to place the work. Rear catch releases automatically.
4. Adjustable Spurs keep work from slipping.
5. Adjustable Stops are provided to make cuts of predetermined depth.
6. Lifting Spring raises saw out of kerf cut automatically.
7. Uprights are adjustable vertically so that saw will always cut square to the base.
8. Steel parts are nickel plated or coated with baked-on finish to prevent rusting.
9. Detachable steel legs.
10. First quality Back Saw is furnished with No. 60MB Mitre Box.

**STANLEY**

**THE TOOL BOX OF THE WORLD**

---

**STANLEY TOOLS**  
NEW BRITAIN, CONN., U. S. A.

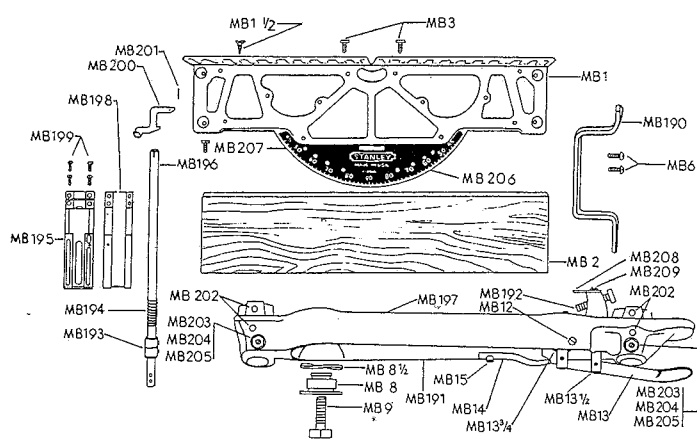

## INSTRUCTIONS FOR ASSEMBLING AND ADJUSTING

**TO SET UP THE MITRE BOX** assemble the upright having the lifting spring (MB194) in the front groove in the swivel arm (MB191) with the two fastening screws (MB202) and the other upright in the rear groove with the catches (MB200) in back.

**TO ADJUST SAW TO CUT TRUE** — The adjusting screws (MB203) are set correctly at the factory. However, if box is purchased without a saw or a saw has been resharpened, and the saw used does not cut true the upright can be tipped slightly left or right by turning the adjusting screw (MB203) in or out. First loosen lock nut (MB204) then loosen fastening screws (MB202), make adjustments, tighten fastening screws, then tighten lock nut.

**A GOOD SAW — ONE THAT IS TRUE, SHARP AND PROPERLY SET — IS AN ESSENTIAL PART OF ANY MITRE BOX. A SAW THAT IS NOT SHARPENED PROPERLY OR IS DULL OR BENT WILL NOT GIVE SATISFACTORY RESULTS.**

**THE SAW GUIDE PLATES (MB198)** are set to use saws of standard thickness. Setting can be increased or decreased by means of screws (MB199).

**STOPS (MB193)** — Each upright is assembled with two stops. The lower one or permanent stop governs the amount the saw cuts (kerf cut) into the frame board (MB2) and the upper one or adjustable stops are used to make cuts of predetermined depths.

**TO SET PERMANENT OR LOWER STOPS (MB193)** run the saw forward until the handle touches the front saw guide. With the adjustable stops loose, fasten the front and rear permanent stops so that with the lifting spring (MB194) compressed the saw will kerf cut into the board about  $\frac{1}{16}$ ". With the lifting spring released the saw should be clear of the kerf cut so that the swivel arm (MB191) can be swung without danger of damaging the saw. It should not be necessary to change this setting unless the depth of the kerf cut is changed.

**THE ADJUSTABLE OR UPPER STOPS (MB193)** are raised up to make cuts of predetermined depths. When not being used they should rest on top of the permanent stops and tightened on the rod. The adjustable stops are set high when leaving the factory to prevent the saw from marring the board before reaching the user, and they should be dropped down before using the Mitre Box.

**SAW GUIDE CATCHES (MB200)** are furnished on both front and rear uprights to hold up the saw when not in use. The front catch is released by hand and the rear one will automatically release by lowering the handle of the saw.

**THE SWIVEL ARM (MB191)** has a tapered index pin (MB13) which engages in holes in the frame at the commonly used angles for cutting 4, 5, 6, 8, and 12 sided figures. By tightening screw (MB192) located just in back of the front upright against the frame the swivel arm can be held stationary at any other angle desired.

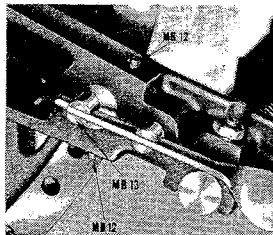

**TO ADJUST SWIVEL ARM HORIZONTALLY** — Index pin (MB13) controls position of swivel arm. It can be adjusted eccentrically with screws (MB12) by turning one out and the other in.

**SPUR SCREWS (MB3)** can be turned out slightly to hold the work from shifting while sawing.

If a panel saw is used place a nail through the small holes in the saw guides which will prevent the saw from riding up, protecting the teeth from striking the guides. Best results, however, are obtained with a back saw