

STANLEY[®]

Garage**Workshop**

20" Deep XL Shelving Cabinet

Armoire profondeur XL 20"

Armario profundo de estantes XL, de 20"

T3

Assembly instructions

Instructions d'assemblage

Instrucciones de armado

T3



Thank you for purchasing the Stanley Garage Workshop Storage System. This is an innovative system that expands as your needs grow, allowing you to purchase additional cabinets as needed to personalize your workshop.

Please follow this assembly instruction booklet to ensure that your cabinets are assembled in the proper manner.

The team at The Stanley Works has taken great care to develop this unique range of cabinets. We are sure you will enjoy owning and using this Garage Workshop product for all of your storage needs.

Since your opinion is important to us, please contact us at the numbers below or visit us at www.stanleyworks.com if you have comments or questions.

Merci d'avoir acheté le système de rangement pour garage Stanley. Ce système innovateur, peut s'agrandir au fur et à mesure de vos besoins. Il vous permet d'acquérir de nouvelles armoires selon vos besoins et de personnaliser votre atelier.

Pour vous assurer un montage correcte des armoires, veuillez suivre les instructions d'assemblage de la brochure.

Toute l'équipe des concepteurs de Stanley a pris soin de développer cette gamme exceptionnelle d'armoires de rangement. Nous sommes sûrs que vous apprécierez l'utilisation de ce système pour atelier et garage, pour tous vos besoins de rangements. Votre avis est important à nos yeux, c'est pourquoi nous vous demandons de bien vouloir nous contacter aux numéros de téléphone ci-dessous ou nous rendre visite sur notre site www.stanleyworks.com pour toute question ou commentaire.

Gracias por comprar el Sistema de almacenamiento para el taller del garaje de Stanley. Éste es un sistema innovador, expandible para adecuarse a sus necesidades, lo cual le permite comprar armarios adicionales a medida que los vaya precisando para personalizar su taller.

Por favor, lea con atención este manual de instrucciones de armado para asegurarse de ensamblar los armarios de la manera correcta.

El equipo de The Stanley Works ha tomado todas las precauciones necesarias para desarrollar esta exclusiva gama de armarios. Estamos seguros de que se sentirá orgulloso como propietario de este producto y que disfrutará utilizándolo en el taller de su garaje para satisfacer todas sus necesidades de almacenamiento. Como su opinión nos es de suma importancia, sírvase contactarse con nosotros a los números indicados a continuación o visítenos en la Internet. www.stanleyworks.com si desea realizar algún comentario o hacer alguna pregunta.



USA/Canada: 1-800-STANLEY
Belgium: +32 15 47 38 50
Denmark & Sweden: +46 49 76 27 77
Finland: +385 9 415 99 100
France: +33 (0) 3 81 66 36 04
Germany: + 49 (0) 421 59 87 77
Italy: +39 039 23 89 703
Netherlands: +31 (0) 800 023 21 69
Spain and Portugal: +34 934 150 268
Switzerland: +41 (0) 44 802 80 90
United Kingdom: + 44 (0) 160 482 7295

Max 390 lb / 180 kg

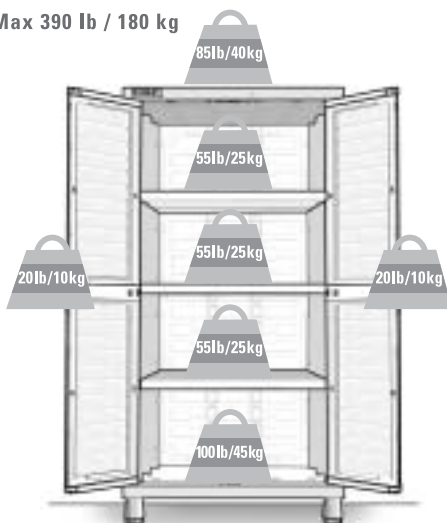



Top x 1
H1200197

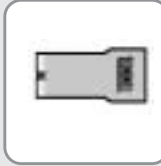

Door connector x 2
H2500444



Top Connector x 4
H2500321



Bottom x 1
H1800019



Door handle x 2
H1400090



Door bin x 6
H2500440



Side x 4
H1100334



Leg x 4
H2200038

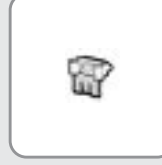

Omega pin x 2
H2300069



Shelf x 3
H2200035



Mid leg x1
H2200031



Axis pin x 4
H2300068



Back board A x 2
H1100335



Front connector x 2
H2500447



Mid axis pin x 2
H2300070

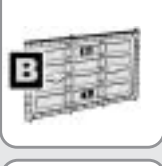

Back board B x 2
H1100336



Back connector x 2
H2500446



Hanging accessories set x 1
P2600528



Door x 2
H2500445-1



Screws x 16
P2600296



Door x 2
H2500445-2

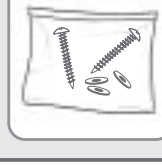

Wall connecting kit x 1
P2600306



 **Do not attach wheels!**
Ne pas assembler les roues !
¡No le coloque ruedas!

Tools for Assembly / Outils pour l'assemblage / Herramientas para el armado
(not included, non inclus, no incluidas)

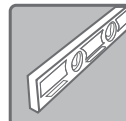



Bottom x 1
H1800019



Leg x 4
H2200038



Mid leg x 1
H2200031



Side x 2
H1100334

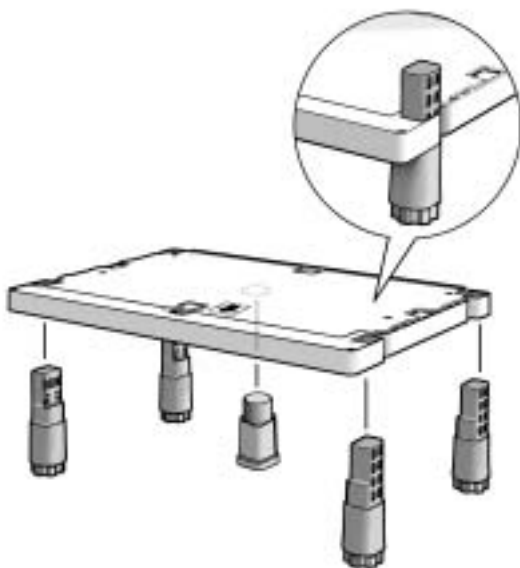

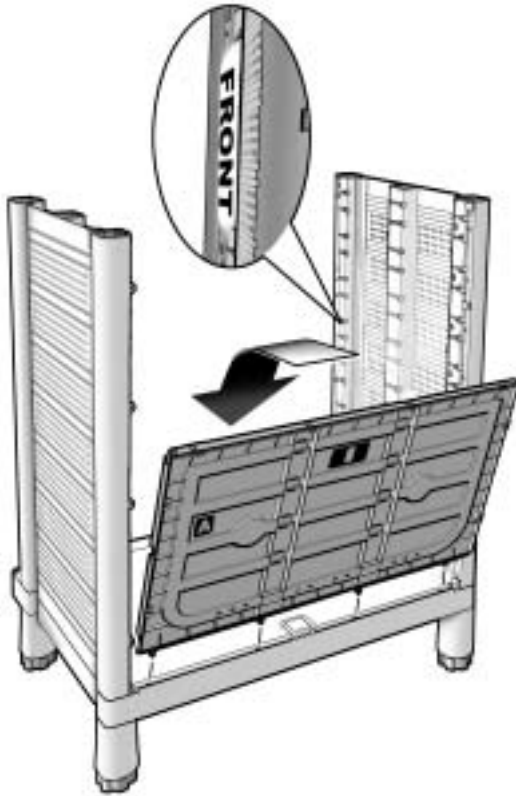

Back x 1
H1100335

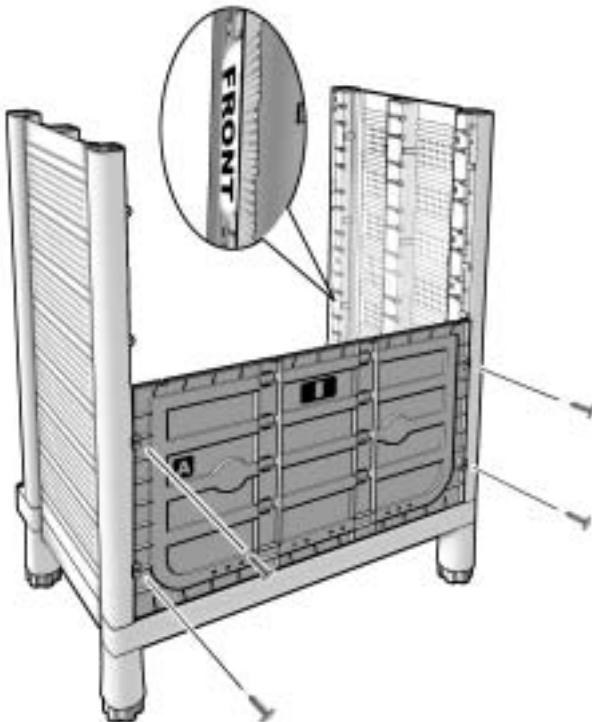

Screws x 4
P2600296

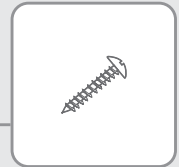

If electric screwdriver is used – adjust to low torque and slow speed.



Si vous utilisez un tournevis électrique, réglez-le sur vitesse et rotation lente.

Si se utiliza un destornillador eléctrico, regúlelo de tal manera que la velocidad y el par de torsión sean bajos.

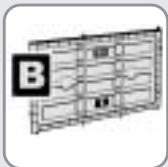

Back x 1
H1100336

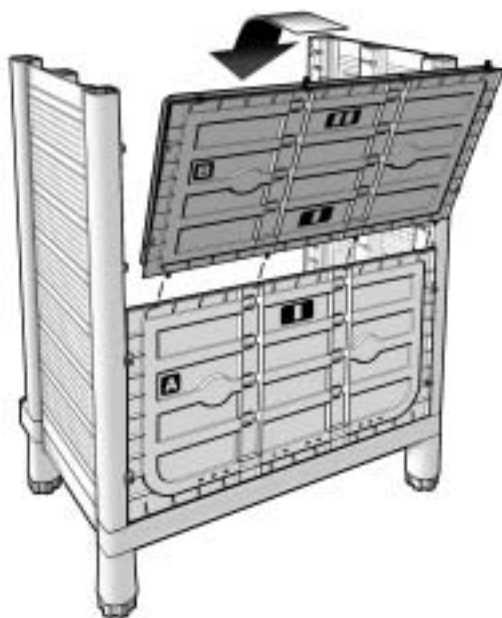

Screws x 4
P2600296



If electric screwdriver is used –
adjust to low torque and slow
speed.



Si vous utilisez un tournevis
électrique, réglez-le sur vitesse
et rotation lente.

Si se utiliza un destornillador
eléctrico, regúlelo de tal manera
que la velocidad y el par de
torsión sean bajos.

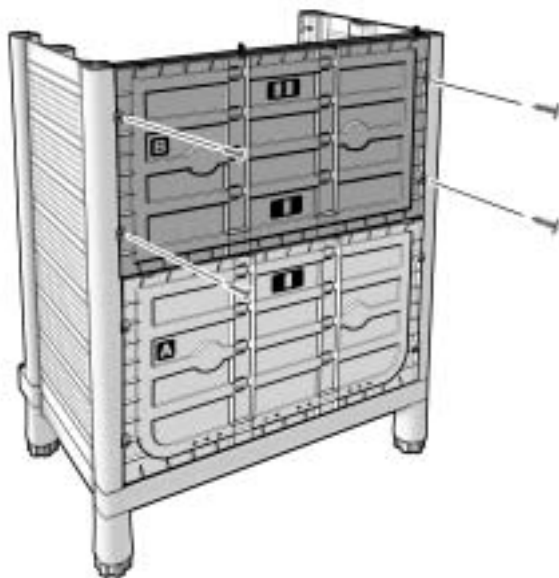

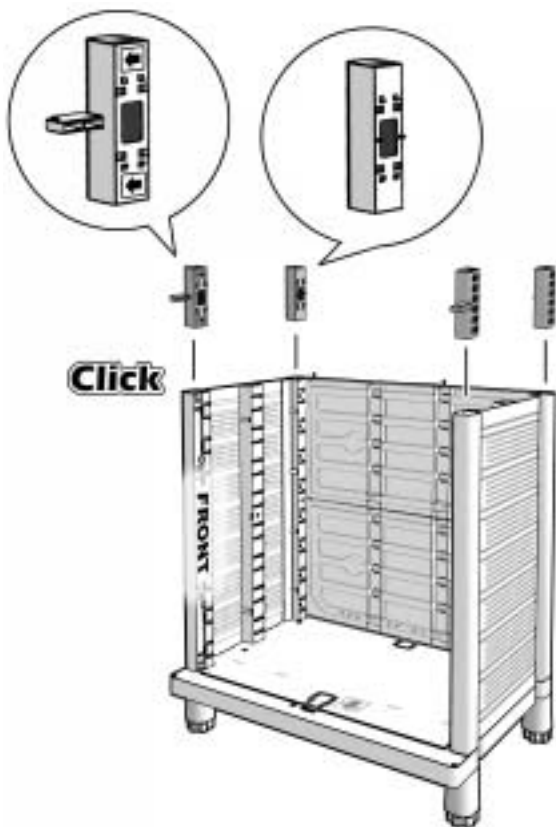

Back
connector
x 2
H2500446



Front
connector
x 2
H2500447

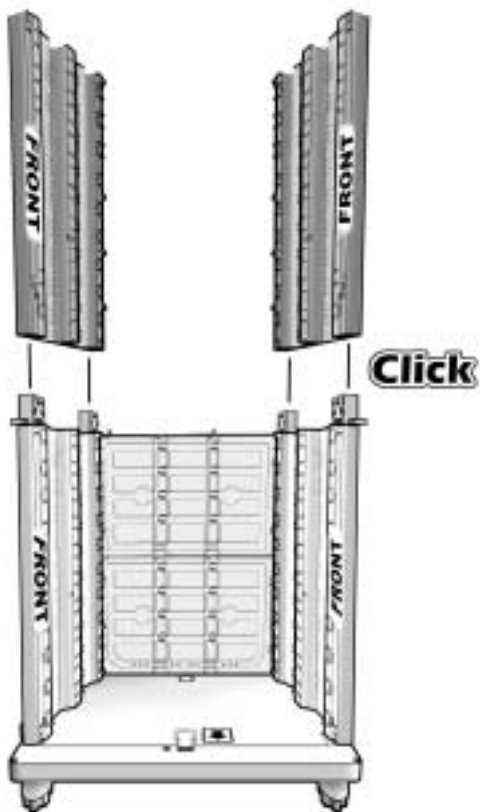

Side x 2
H1100334

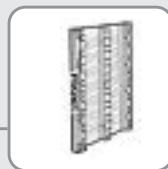



Back x 1
H1100336

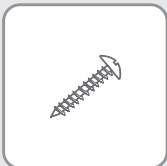
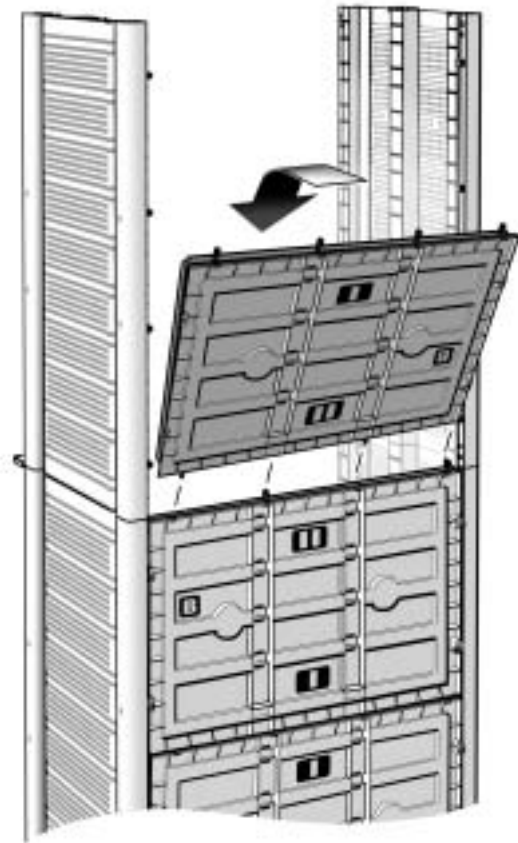

Screws x 4
P2600296

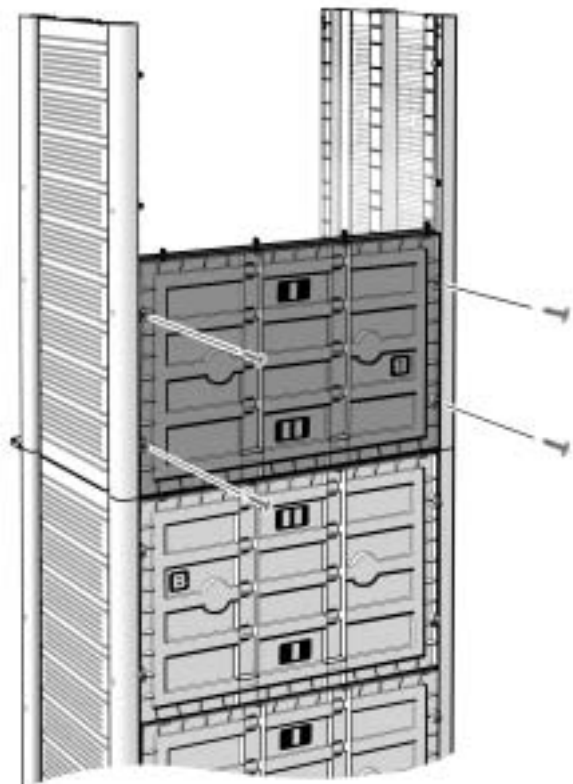

If electric screwdriver is used –
adjust to low torque and slow
speed.

Si vous utilisez un tournevis
électrique, réglez-le sur vitesse
et rotation lente.



Si se utiliza un destornillador
eléctrico, regúlelo de tal manera
que la velocidad y el par de
torsión sean bajos.

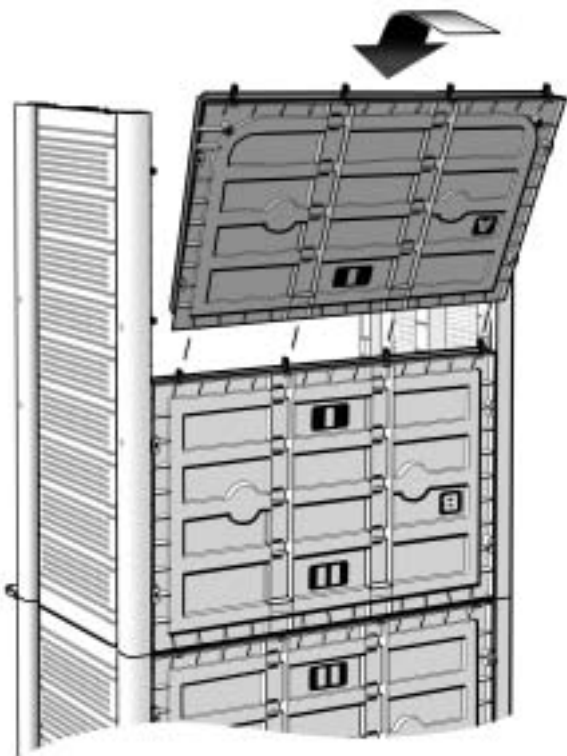

Back x 1
H1100335

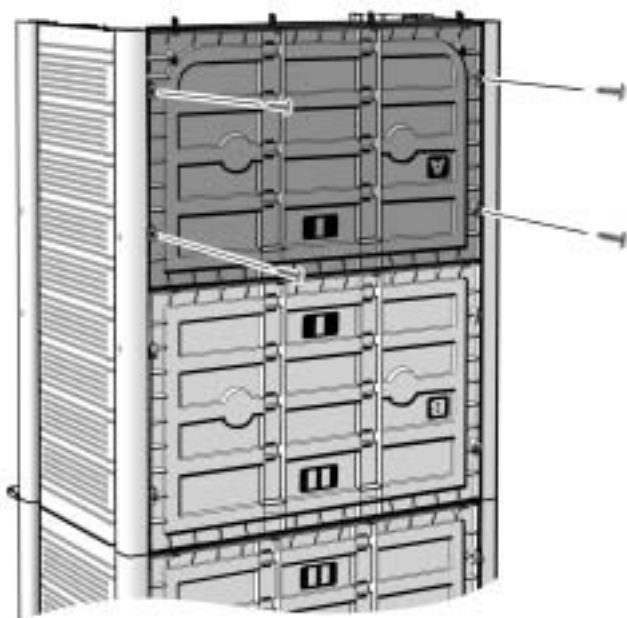

Screws x 4
P2600296



If electric screwdriver is used – adjust to low torque and slow speed.



Si vous utilisez un tournevis électrique, réglez-le sur vitesse et rotation lente.

Si se utiliza un destornillador eléctrico, regúlelo de tal manera que la velocidad y el par de torsión sean bajos.



Top x 1
H1200197

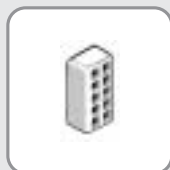

Top
Connector
x 4
H2500321

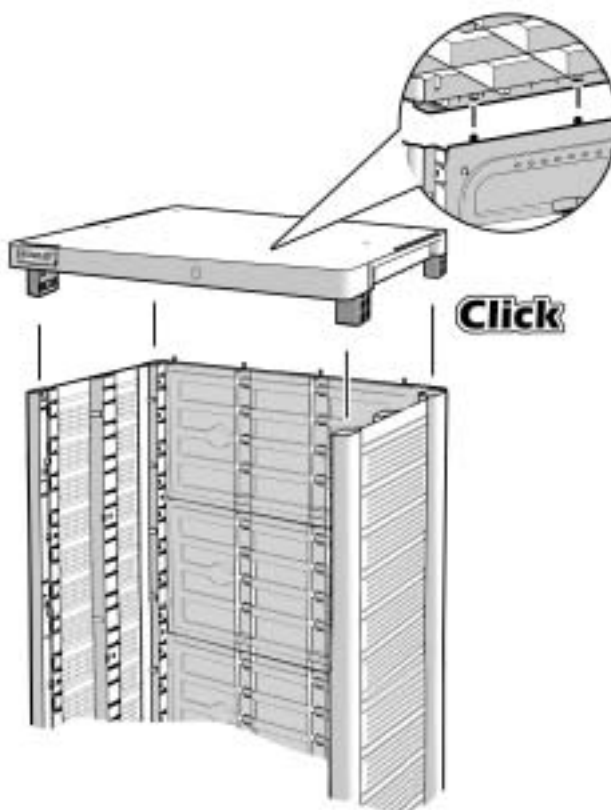
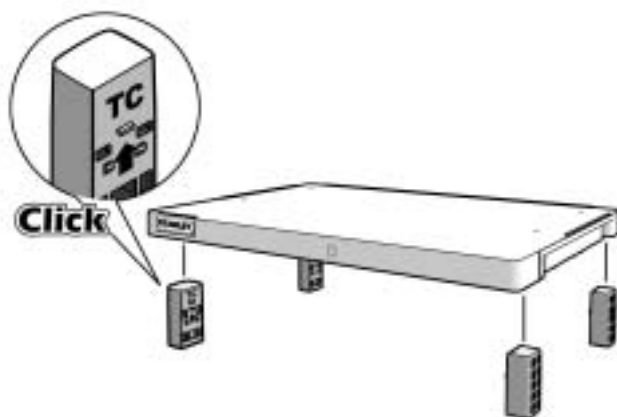

Lay cabinet on the floor while inserting shelves.
Poser l'armoire au sol pour y introduire les étagères.
Apoye el armario sobre el piso mientras inserta los estantes.

Shelf x 3
H2200035

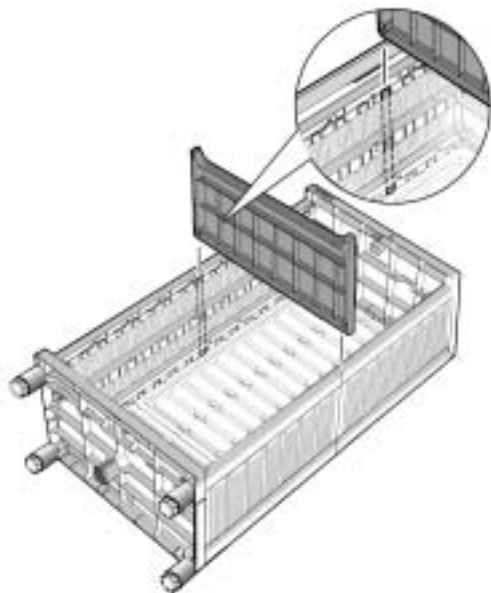

Position one of the shelves in the middle of cabinet – to assure stability of unit.

Positionner une des étagères au milieu de l'armoire pour assurer la stabilité de l'unité.

Ubique uno de los estantes en la mitad del armario, para garantizar la estabilidad de la unidad.

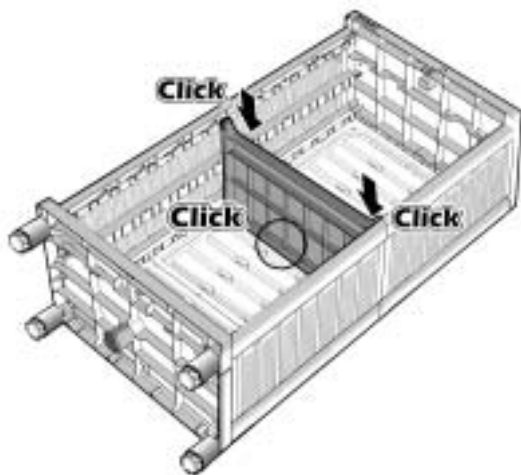

The adjustable shelves have 20 possible positions, allowing for complete flexibility. For repositioning shelves, release front and rear snaps.

Etagères ajustables sur 20 positions possibles pour une très grande souplesse de rangement. Pour repositionner les étagères – libérer les buttoirs avant et arrière.

Los estantes regulables tienen 20 posiciones posibles, lo cual brinda absoluta flexibilidad. Para reubicar los estantes, suelte los ganchos delanteros y traseros.

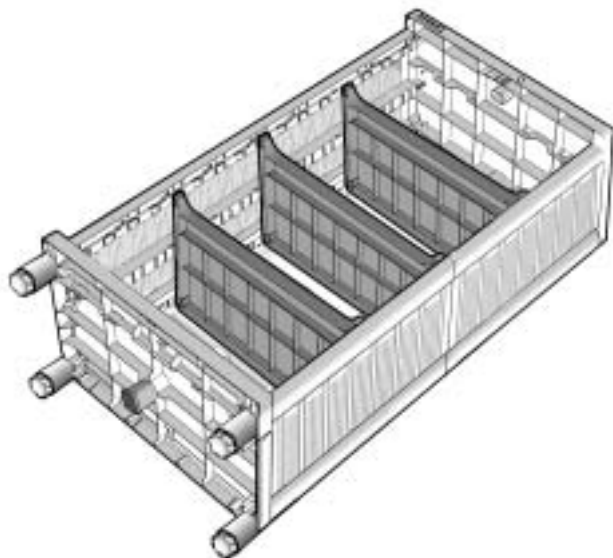



Metal panels have sharp edges! Wear gloves to protect your hands from cuts.

Les panneaux métalliques ont des bords acérés! Le port de gants est recommandé pour éviter les coupures.



¡Los paneles metálicos tienen bordes filosos! Use guantes para protegerse las manos.



Door x 2
H2500445-1



Door x 2
H2500445-2



Door
connector
x 2
H2500444



Handle x 2
H1400090



Axis pin x 4
H2300068



Mid axis
pin x 2
H2300070

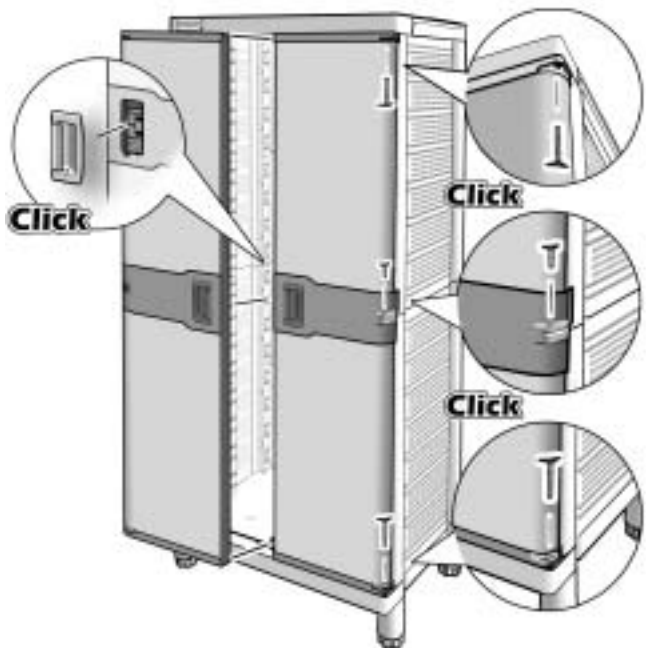
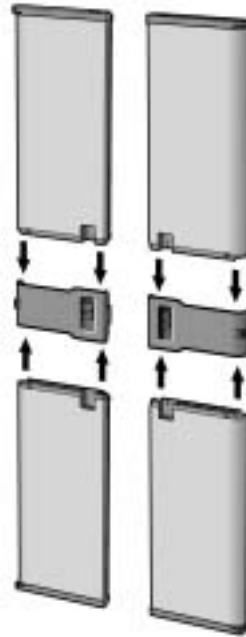



For door reassembly - use screwdriver to detach axis pin.



Pour l'assemblage de la porte – Utiliser un tournevis pour détacher la goupille d'axe.

Para volver a armar la puerta, use un destornillador para desprender el perno del eje.

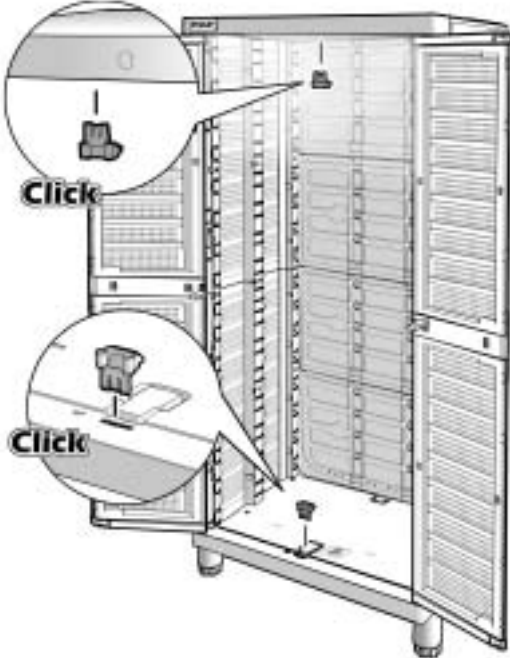
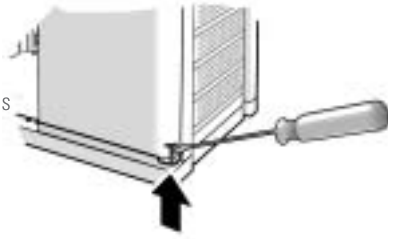

Omega
pin x 2

H2300069

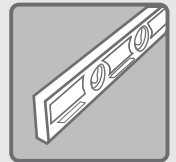
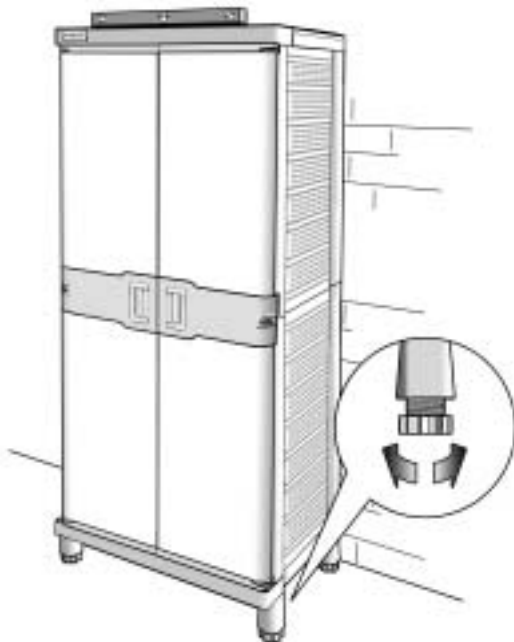



Wall
connecting
kit x 1
H2500440



If electric screwdriver is used –
adjust to low torque and slow
speed.



Si vous utilisez un tournevis
électrique, réglez-le sur vitesse
et rotation lente.

Si se utiliza un destornillador
eléctrico, regúlelo de tal manera
que la velocidad y el par de
torsión sean bajos.

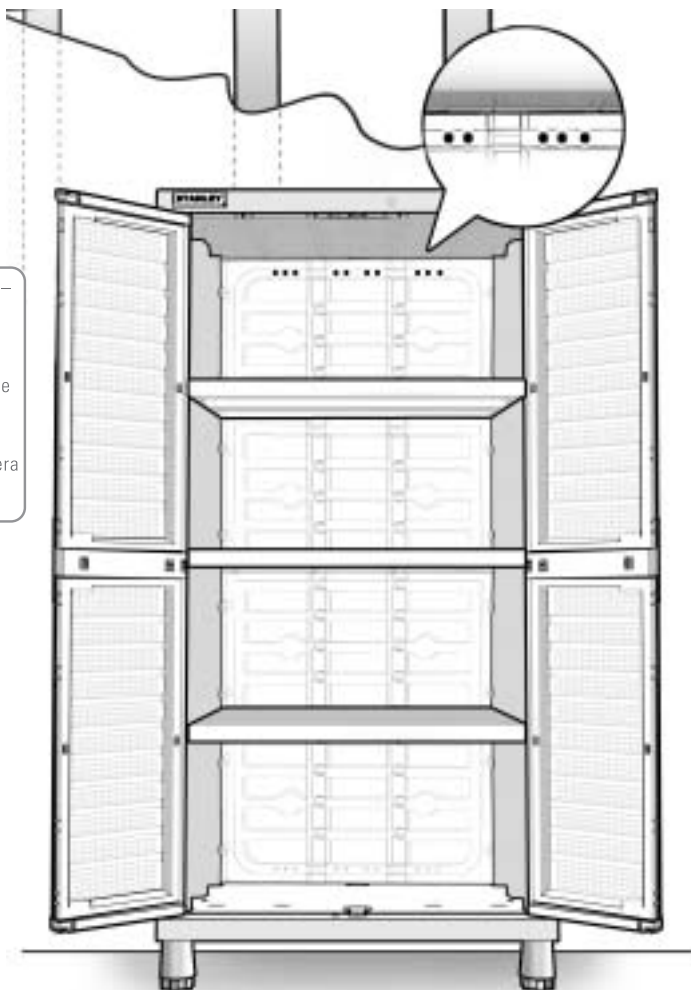

- Connect the cabinet to wall studs to avoid tipping over!
Note! Use fittings and screws that are suited to your wall type – parts for wood and metal studded walls are included.
For other wall types – contact your local specialized retailer to determine the proper hardware.

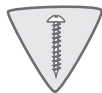

- Fixer l'armoire au mur à l'aide des fixations murales pour éviter qu'elle ne tombe !
Note ! Utiliser des attaches et des vis convenant au matériau de votre mur – des pièces pour la fixation sur des murs en bois ou en métal sont incluses.
Pour les autres types de murs – contactez votre revendeur local spécialisé pour déterminer les attaches appropriées.

- ¡Sujete el armario a las vigas para la pared para evitar que se tumbe!
¡Nota importante! Utilice aquellos accesorios y tornillos que sean adecuados para su tipo de pared. Se incluyen partes para paredes con vigas de metal y madera.
Para otros tipos de paredes, contáctese con su minorista local especializado para determinar las piezas adecuadas.

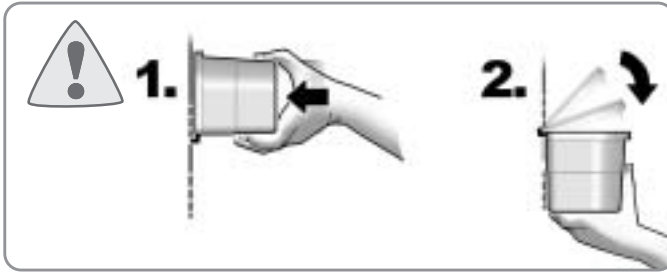

Bin x 6
H2500440

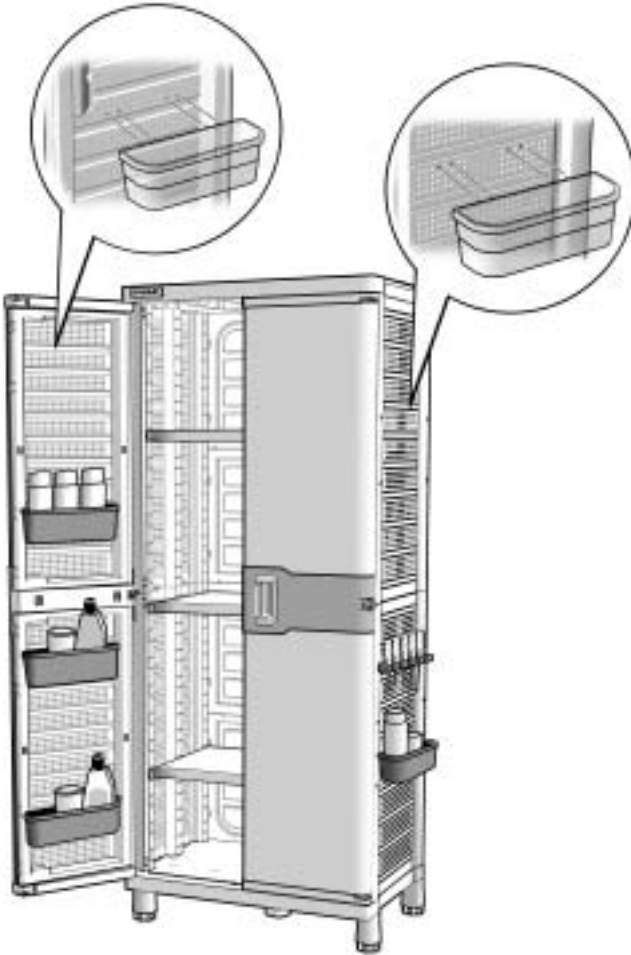

Hanging
accessories
set x 1
P2600528

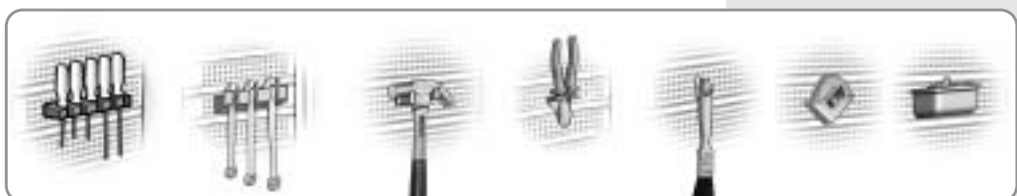

STANLEY GarageWorkshop



Now you can enjoy your new Stanley Garage Workshop cabinet.
Thank you for choosing our product and do not forget to visit our web site at **www.stanleyworks.com**, where you will find an innovative planning tool and many informative tips, to help you design your own dream workshop.

Vous pouvez maintenant apprécier votre nouvel atelier de garage équipé Stanley.
Merci d'avoir choisi notre produit. N'oubliez pas de vous rendre sur notre site Internet **www.stanleyworks.com** où vous trouverez des solutions de rangement novatrices ainsi que de nombreux conseils et informations pour vous aider à concevoir l'atelier dont vous rêvez.

Ahora puede disfrutar de su nuevo armario para el taller del garaje Stanley.
Gracias por elegir nuestro producto y no se olvide de visitar nuestro sitio web en **www.stanleyworks.com**, donde encontrará innovadoras herramientas y muchos consejos informativos que le servirán para diseñar el taller propio de sus sueños.

0 76174 93340 6

In Mexico Imported By:
En México Importado Por:
Au Mexique Importé Par :
Stanley Bostitch, S.A. de C.V.
Av. de Los Ángeles No. 303 Interior Local 1-C
Col. San Martín Xochinahuac
Delegación Azcapotzalco
México, D.F., C.P. 02120
R.F.C. SBO-861201-7z5

©2005 The Stanley Works, New Britain, CT 06053 U.S.A

